

Lecture 24

Circuit Theory Revisited

Circuit theory is one of the most successful and often used theories in electrical engineering. Its success is mainly due to its simplicity: it can capture the physics of highly complex circuits and structures, which is very important in the computer and micro-chip industry (or the IC design industry). Simplicity rules! Now, having understood electromagnetic theory in its full glory, it is prudent to revisit circuit theory and study its relationship to electromagnetic theory [31, 32, 54, 65].

The two most important laws in circuit theory are Kirchoff current law (KCL) and Kirchoff voltage law (KVL) [14, 52]. These two laws are derivable from the current continuity equation and from Faraday's law.

24.1 Kirchoff Current Law

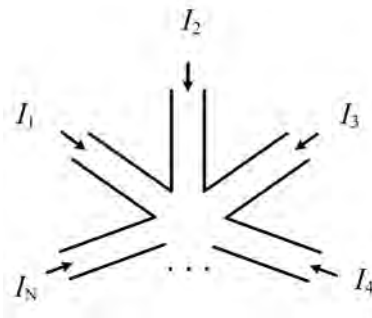

Figure 24.1: Schematic showing the derivation of Kirchoff current law. All currents flowing into a node must add up to zero.

Kirchhoff current law (KCL) is a consequence of the current continuity equation, or that

$$\nabla \cdot \mathbf{J} = -j\omega\rho \quad (24.1.1)$$

It is a consequence of charge conservation. But it is also derivable from generalized Ampere's law and Gauss' law for charge.¹

First, we assume that all currents are flowing into a node as shown in Figure 24.1, and that the node is non-charge accumulating with $\omega \rightarrow 0$. Then the charge continuity equation becomes²

$$\nabla \cdot \mathbf{J} = 0 \quad (24.1.2)$$

By integrating the above current continuity equation over a volume containing the node, it is easy to show that

$$\sum_i^N I_i = 0 \quad (24.1.3)$$

which is the statement of KCL. This is shown for the schematic of Figure 24.1.

24.2 Kirchhoff Voltage Law

Kirchhoff voltage law is the consequence of Faraday's law. For the truly static case when $\omega = 0$, it is

$$\nabla \times \mathbf{E} = 0 \quad (24.2.1)$$

The above implies that $\mathbf{E} = -\nabla\Phi$, from which we can deduce that

$$-\oint_C \mathbf{E} \cdot d\mathbf{l} = 0 \quad (24.2.2)$$

For statics, the statement that $\mathbf{E} = -\nabla\Phi$ also implies that we can define a voltage drop between two points, a and b to be

$$V_{ba} = -\int_a^b \mathbf{E} \cdot d\mathbf{l} = \int_a^b \nabla\Phi \cdot d\mathbf{l} = \Phi(\mathbf{r}_b) - \Phi(\mathbf{r}_a) = V_b - V_a \quad (24.2.3)$$

The equality $\int_a^b \nabla\Phi \cdot d\mathbf{l} = \Phi(\mathbf{r}_b) - \Phi(\mathbf{r}_a)$ can be understood by expressing this integral in one dimension along a straight line segment, or that

$$\int_a^b \frac{d}{dx} \Phi \cdot d\mathbf{x} = \Phi(\mathbf{r}_b) - \Phi(\mathbf{r}_a) \quad (24.2.4)$$

¹Some authors will say that charge conservation is more fundamental, and that Gauss' law and Ampere's law are consistent with charge conservation and the current continuity equation.

²One can also say that this is a consequenc of static Ampere's law, $\nabla \times \mathbf{H} = \mathbf{J}$. By taking the divergence of this equation yields (24.1.2) directly.

A curved line can be thought of as a concatenation of many small straight line segments.

As has been shown before, to be exact, $\mathbf{E} = -\nabla\Phi - \partial/\partial t\mathbf{A}$, but we have ignored the induction effect. Therefore, this concept is only valid in the low frequency or long wavelength limit, or that the dimension over which the above is applied is very small so that retardation effect can be ignored.

A good way to remember the above formula is that if $V_b > V_a$. Since $\mathbf{E} = -\nabla\Phi$, then the electric field points from point a to point b : Electric field always points from the point of higher potential to point of lower potential. Faraday’s law when applied to the static case for a closed loop of resistors shown in Figure 24.2 gives Kirchoff voltage law (KVL), or that

$$\sum_i^N V_j = 0 \tag{24.2.5}$$

Notice that the voltage drop across a resistor is always positive, since the voltages to the left of the resistors in Figure 24.2 are always higher than the voltages to the right of the resistors. This implies that internal to the resistor, there is always an electric field that points from the left to the right.

If one of the voltage drops is due to a voltage source, it can be modeled by a negative resistor as shown in Figure 24.3. The voltage drop across a negative resistor is opposite to that of a positive resistor. As we have learn from the Poynting’s theorem, negative resistor gives out energy instead of dissipates energy.

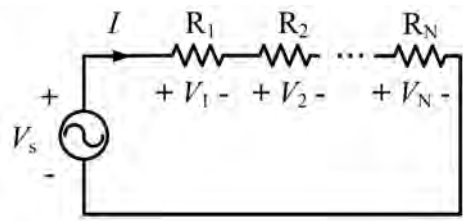

Figure 24.2: Kichhoff voltage law where the sum of all voltages around a loop is zero, which is the consequence of static Faraday’s law.

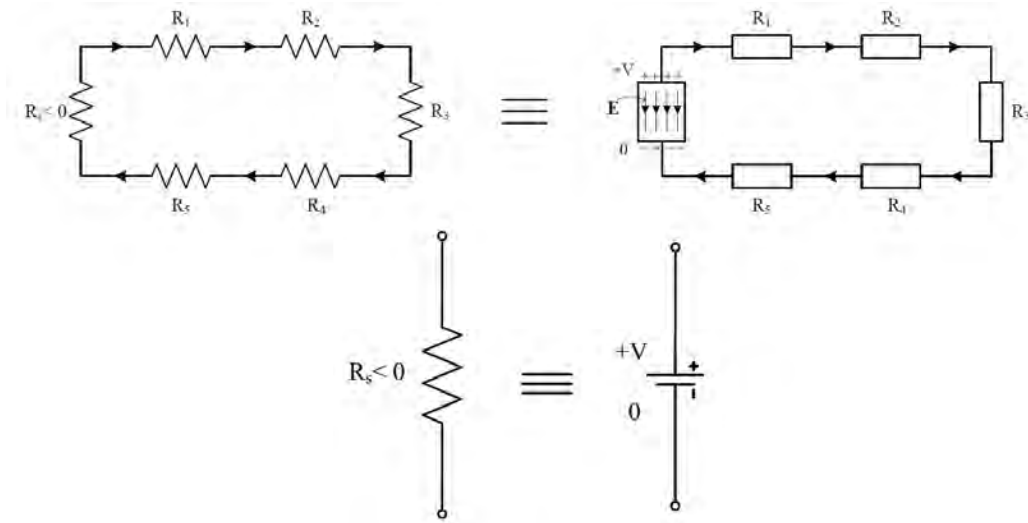

Figure 24.3: A voltage source can also be modeled by a negative resistor.

Faraday's law for the time-varying \mathbf{B} flux case is

$$\nabla \times \mathbf{E} = -\frac{\partial \mathbf{B}}{\partial t} \quad (24.2.6)$$

Writing the above in integral form, one gets

$$-\oint_C \mathbf{E} \cdot d\mathbf{l} = \frac{d}{dt} \int_s \mathbf{B} \cdot d\mathbf{S} \quad (24.2.7)$$

We can apply the above to a loop shown in Figure 24.4, or a loop C that goes from a to b to c to d to a . We can further assume that this loop is very small compared to wavelength so that potential theory that $\mathbf{E} = -\nabla\Phi$ can be applied. Furthermore, we assume that this loop C does not have any magnetic flux through it so that the right-hand side of the above can be set to zero, or

$$-\oint_C \mathbf{E} \cdot d\mathbf{l} = 0 \quad (24.2.8)$$

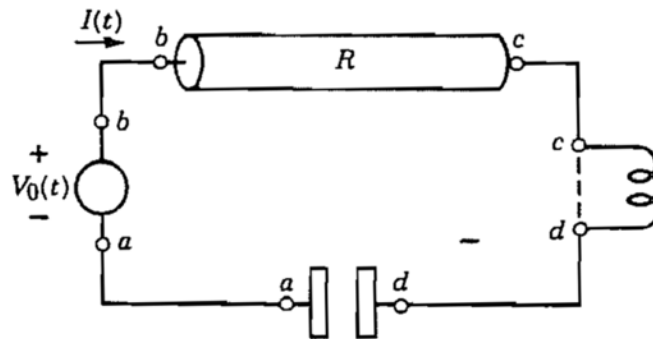

Figure 24.4: The Kirchhoff voltage law for a circuit loop consisting of resistor, inductor, and capacitor can also be derived from Faraday’s law at low frequency (courtesy of Ramo et al).

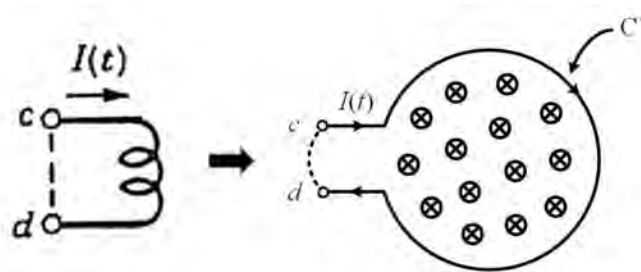

Figure 24.5: The voltage-current relation of an inductor can be obtained by unwrapping an inductor coil, and then calculating its flux linkage.

Notice that this loop does not go through the inductor, but goes directly from c to d . Then there is no flux linkage in this loop and thus

$$-\int_a^b \mathbf{E} \cdot d\mathbf{l} - \int_b^c \mathbf{E} \cdot d\mathbf{l} - \int_c^d \mathbf{E} \cdot d\mathbf{l} - \int_d^a \mathbf{E} \cdot d\mathbf{l} = 0 \tag{24.2.9}$$

Inside the source or the battery, it is assumed that the electric field points opposite to the direction of integration $d\mathbf{l}$, and hence the first term on the left-hand side of the above is positive and equal to $V_0(t)$, while the other terms are negative. Writing out the above more explicitly, after using (24.2.3), we have

$$V_0(t) + V_{cb} + V_{dc} + V_{ad} = 0 \tag{24.2.10}$$

Notice that in the above, in accordance to (24.2.3), $V_b > V_c$, $V_c > V_d$, and $V_a > V_d$. Therefore, V_{cb} , V_{dc} , and V_{ad} are all negative quantities but $V_0(t) > 0$. We will study the contributions to each of the terms, the inductor, the capacitor, and the resistor more carefully next.

24.3 Inductor

To find the voltage current relation of an inductor, we apply Faraday's law to a closed loop C' formed by dc and the inductor coil shown in the Figure 24.5 where we have unwrapped the solenoid into a larger loop. Assume that the inductor is made of a perfect conductor, so that the electric field \mathbf{E} in the wire is zero. Then the only contribution to the left-hand side of Faraday's law is the integration from point d to point c , the only place in the loop C' where \mathbf{E} is not zero. We assume that outside the loop in the region between c and d , potential theory applies, and hence, $\mathbf{E} = -\nabla\Phi$. Now, we can connect V_{dc} in the previous equation to the flux linkage to the inductor. When the voltage source attempts to drive an electric current into the loop, Lenz's law (1834)³ comes into effect, essentially, generating an opposing voltage. The opposing voltage gives rise to charge accumulation at d and c , and therefore, a low frequency electric field at the gap at dc .

To this end, we form a new C' that goes from d to c , and then continue onto the wire that leads to the inductor. But this new loop will contain the flux \mathbf{B} generated by the inductor current. Thus

$$\oint_{C'} \mathbf{E} \cdot d\mathbf{l} = \int_d^c \mathbf{E} \cdot d\mathbf{l} = -V_{dc} = -\frac{d}{dt} \int_{S'} \mathbf{B} \cdot d\mathbf{S} \quad (24.3.1)$$

As mentioned before, since the wire is a PEC, the integration around the loop C' is only nonzero from d to c . In the above, $\int_{S'} \mathbf{B} \cdot d\mathbf{S}$ is the flux linkage. The inductance L is defined as the flux linkage per unit current, or

$$L = \left[\int_{S'} \mathbf{B} \cdot d\mathbf{S} \right] / I \quad (24.3.2)$$

So the voltage in (24.3.1) is then

$$V_{dc} = \frac{d}{dt}(LI) = L \frac{dI}{dt} \quad (24.3.3)$$

since L is time independent.

Had there been a finite resistance in the wire of the inductor, then the electric field is non-zero inside the wire. Taking this into account, we have

$$\oint \mathbf{E} \cdot d\mathbf{l} = R_L I - V_{dc} = -\frac{d}{dt} \int_S \mathbf{B} \cdot d\mathbf{S} \quad (24.3.4)$$

Consequently,

$$V_{dc} = R_L I + L \frac{dI}{dt} \quad (24.3.5)$$

Thus, to account for the loss of the coil, we add a resistor in the equation. The above becomes simpler in the frequency domain, namely

$$V_{dc} = R_L I + j\omega L I \quad (24.3.6)$$

³Lenz's law can also be explained from Faraday's law (1831).

24.4 Capacitance

The capacitance is the proportionality constant between the charge Q stored in the capacitor, and the voltage V applied across the capacitor, or $Q = CV$. Then

$$C = \frac{Q}{V} \quad (24.4.1)$$

From the current continuity equation, one can easily show that in Figure 24.6,

$$I = \frac{dQ}{dt} = \frac{d}{dt}(CV_{da}) = C \frac{dV_{da}}{dt} \quad (24.4.2)$$

where C is time independent. Integrating the above equation, one gets

$$V_{da}(t) = \frac{1}{C} \int_{-\infty}^t I dt' \quad (24.4.3)$$

The above looks quite cumbersome in the time domain, but in the frequency domain, it becomes

$$I = j\omega CV_{da} \quad (24.4.4)$$

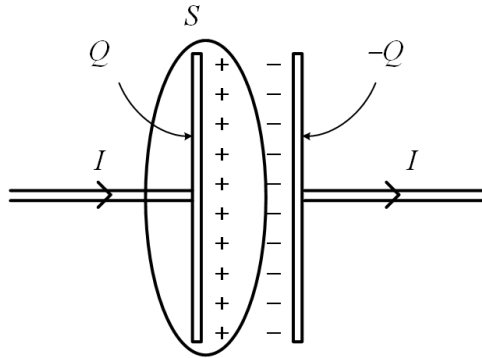

Figure 24.6: Schematic showing the calculation of the capacitance of a capacitor.

24.5 Resistor

The electric field is not zero inside the resistor as electric field is needed to push electrons through it. As discussed in Section 8.3, a resistor is a medium where collision dominates. As is well known,

$$\mathbf{J} = \sigma \mathbf{E} \quad (24.5.1)$$

where σ is the conductivity of the medium. From this, we deduce that $V_{cb} = V_c - V_b$ is a negative number given by

$$V_{cb} = - \int_b^c \mathbf{E} \cdot d\mathbf{l} = - \int_b^c \frac{\mathbf{J}}{\sigma} \cdot d\mathbf{l} \quad (24.5.2)$$

where we assume a uniform current $\mathbf{J} = \hat{l}I/A$ in the resistor where \hat{l} is a unit vector pointing in the direction of current flow in the resistor. We can assume that I is a constant along the length of the resistor, and thus, $\mathbf{J} \cdot d\mathbf{l} = Idl/A$, implying that

$$V_{cb} = - \int_b^c \frac{Idl}{\sigma A} = -I \int_b^c \frac{dl}{\sigma A} = -IR \quad (24.5.3)$$

where⁴

$$R = \int_b^c \frac{dl}{\sigma A} = \int_b^c \frac{\rho dl}{A} \quad (24.5.4)$$

Again, for simplicity, we assume long wavelength or low frequency in the above derivation.

24.6 Some Remarks

In this course, we have learnt that given the sources ρ and \mathbf{J} of an electromagnetic system, one can find Φ and \mathbf{A} , from which we can find \mathbf{E} and \mathbf{H} . This is even true at DC or statics. We have also looked at the definition of inductor L and capacitor C . But clever engineering is driven by heuristics: it is better, at times, to look at inductors and capacitors as energy storage devices, rather than flux linkage and charge storage devices.

Another important remark is that even though circuit theory is simpler than Maxwell's equations in its full glory, not all the physics is lost in it. The physics of the induction term in Faraday's law and the displacement current term in generalized Ampere's law are still retained and amplified by capacitor and inductor, respectively. In fact, wave physics is still retained in circuit theory: one can make slow wave structure out a series of inductors and capacitors. The lumped-element model of a transmission line is an example of a slow-wave structure design. Since the wave is slow, it has a smaller wavelength, and resonators can be made smaller: We see this in the LC tank circuit which is a much smaller resonator in wavelength with $L/\lambda \ll 1$ compared to a microwave cavity resonator for instance. Therefore, circuit design is great for miniaturization. The short coming is that inductors and capacitors generally have higher losses than air or vacuum.

24.7 Energy Storage Method for Inductor and Capacitor

Often time, it is more expedient to think of inductors and capacitors as energy storage devices. This enables us to identify stray (also called parasitic) inductances and capacitances more

⁴The resistivity $\rho = 1/\sigma$ where ρ has the unit of ohm-m, while σ has the unit of siemen/m.

easily. This manner of thinking allows for an alternative way of calculating inductances and capacitances as well [31].

The energy stored in an inductor is due to its energy storage in the magnetic field, and it is alternatively written, according to circuit theory, as

$$W_m = \frac{1}{2}LI^2 \quad (24.7.1)$$

Therefore, it is simpler to think that an inductance exists whenever there is stray magnetic field to store magnetic energy. A piece of wire carries a current that produces a magnetic field enabling energy storage in the magnetic field. Hence, a piece of wire in fact behaves like a small inductor, and it is non-negligible at high frequencies: Stray inductances occur whenever there are stray magnetic fields.

By the same token, a capacitor can be thought of as an electric energy storage device rather than a charge storage device. The energy stored in a capacitor, from circuit theory, is

$$W_e = \frac{1}{2}CV^2 \quad (24.7.2)$$

Therefore, whenever stray electric field exists, one can think of stray capacitances as we have seen in the case of fringing field capacitances in a microstrip line.

24.8 Finding Closed-Form Formulas for Inductance and Capacitance

Finding closed form solutions for inductors and capacitors is a difficult endeavor. As in solving Maxwell's equations or the waveguide problem, only certain geometries are amenable to closed form solutions. Even a simple circular loop does not have a closed form solution for its inductance L . If we assume a uniform current on a circular loop, in theory, the magnetic field can be calculated using Bio-Savart law that we have learnt before, namely that

$$\mathbf{H}(\mathbf{r}) = \int \frac{I(\mathbf{r}')d\mathbf{l}' \times \hat{R}}{4\pi R^2} \quad (24.8.1)$$

But the above cannot be evaluated in closed form save in terms of complicate elliptic integrals [117,133]. Thus it is simpler to just measure the inductance.

However, if we have a solenoid as shown in Figure 24.7, an approximate formula for the inductance L can be found if the fringing field at the end of the solenoid can be ignored. The inductance can be found using the flux linkage method [29,31]. Figure 24.8 shows the schematic used to find the approximate inductance of this inductor.

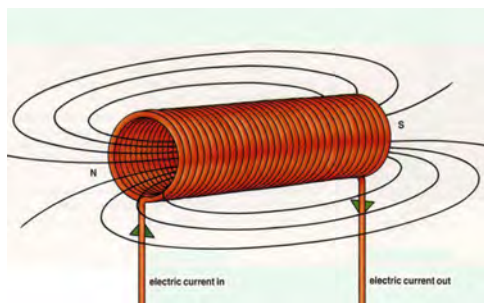

Figure 24.7: The flux-linkage method is used to estimate the inductor of a solenoid (courtesy of SolenoidSupplier.Com).

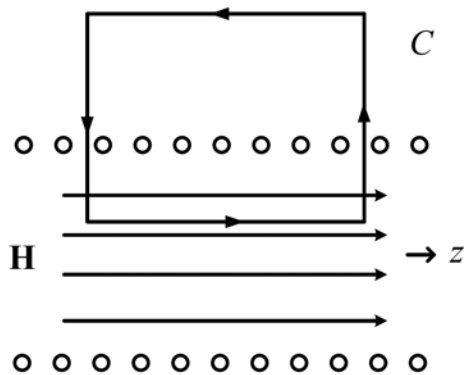

Figure 24.8: Finding the inductor flux linkage approximately by assuming the magnetic field is uniform inside a long solenoid.

The capacitance of a parallel plate capacitor can be found by solving a boundary value problem (BVP) for electrostatics as shown in Section 3.3.4. The electrostatic BVP for capacitor involves Poisson's equation and Laplace equation which are scalar equations [48]. Alternatively, variational expressions can be used to find the lower and upper bounds of capacitors using, for example, Thomson's theorem [48].

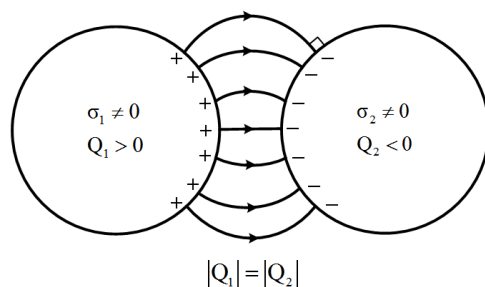

Figure 24.9: The capacitance between two charged conductors can be found by solving a boundary value problem (BVP) involving Laplace equation as discussed in 3.3.4.

Assume a geometry of two conductors charged to $+V$ and $-V$ volts as shown in Figure 24.9. Surface charges will accumulate on the surfaces of the conductors. Using Poisson's equations, and Green's function for Poisson's equation, one can express the potential in between the two conductors as due to the surface charges density $\sigma(\mathbf{r})$. It can be expressed as

$$\Phi(\mathbf{r}) = \frac{1}{\varepsilon} \int_S dS' \frac{\sigma(\mathbf{r}')}{4\pi|\mathbf{r} - \mathbf{r}'|} \quad (24.8.2)$$

where $S = S_1 + S_2$ is the union of two surfaces S_1 and S_2 . Since Φ has values of $+V$ and $-V$ on the two conductors, we require that

$$\Phi(\mathbf{r}) = \frac{1}{\varepsilon} \int_S dS' \frac{\sigma(\mathbf{r}')}{4\pi|\mathbf{r} - \mathbf{r}'|} = \begin{cases} +V, & \mathbf{r} \in S_1 \\ -V, & \mathbf{r} \in S_2 \end{cases} \quad (24.8.3)$$

In the above, $\sigma(\mathbf{r}')$, the surface charge density, is the unknown yet to be sought and it is embedded in an integral. But the right-hand side of the equation is known. Hence, this equation is also known as an integral equation. The integral equation can be solved by numerical methods.

Having found $\sigma(\mathbf{r})$, then it can be integrated to find Q , the total charge on one of the conductors. Since the voltage difference between the two conductors is known, the capacitance can be found as $C = Q/(2V)$.

24.9 Importance of Circuit Theory in IC Design

The clock rate of computer circuits has peaked at about 3 GHz due to the resistive loss, or the I^2R loss. At this frequency, the wavelength is about 10 cm. Since transistors and circuit components are shrinking due to the compounding effect of Moore's law, most components, which are of nanometer dimensions, are much smaller than the wavelength. Thus, most of the physics of electromagnetic signal in a microchip circuit can be captured using circuit theory.

Figure 24.10 shows the schematic and the cross section of a computer chip at different levels: with the transistor level at the bottom-most. The signals are taken out of a transistor by XY lines at the middle level that are linked to the ball-grid array at the top-most level of the chip. And then, the signal leaves the chip via a package. Since these nanometer-size structures are much smaller than the wavelength, they are usually modeled by lumped R , L , and C elements when retardation effect can be ignored. If retardation effect is needed, it is usually modeled by a transmission line. This is important at the package level where the dimensions of the components are larger.

A process of parameter extraction where computer software or field solvers (software that solve Maxwell's equations numerically) are used to extract these lumped-element parameters. Finally, a computer chip is modeled as a network involving a large number of transistors, diodes, and R , L , and C elements. Subsequently, a very useful commercial software called SPICE (Simulation Program with Integrated-Circuit Emphasis) [134], which is a computer-aided software, solves for the voltages and currents in this network.

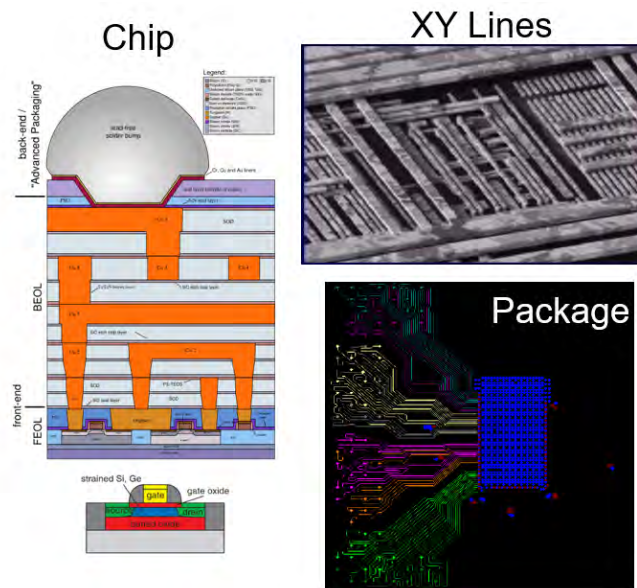

Figure 24.10: Cross section of a chip (top left) and the XY lines in the chip (top right), and the interconnects in the package needed to take the signal out of the chip (bottom right) (courtesy of Wikipedia and Intel).

Initially, SPICE software was written primarily to solve circuit problems. But the SPICE software now has many capabilities, including modeling of transmission lines for microwave engineering, which are important for modeling retardation effects. Figure 24.11 shows an interface of an RF-SPICE that allows the modeling of transmission line with a Smith chart interface.

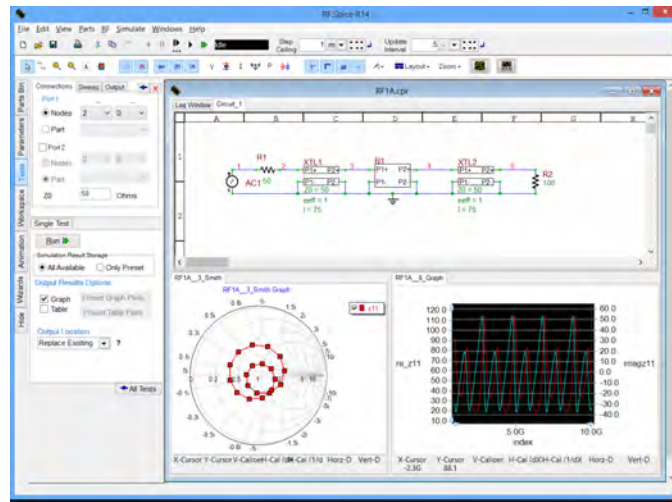

Figure 24.11: SPICE is also used to solve RF problems. A transmission line is used in combination with circuit theory to account for retardation effects in a computer circuit (courtesy of EMAG Technologies Inc.).

24.10 Decoupling Capacitors and Spiral Inductors

Decoupling capacitor is an important part of modern computer chip design. They can regulate voltage supply on the power delivery network of the chip as they can remove high-frequency noise and voltage fluctuation from a circuit as shown in Figure 24.12. Figure 24.13 shows a 3D IC computer chip where decoupling capacitors are integrated into its design.

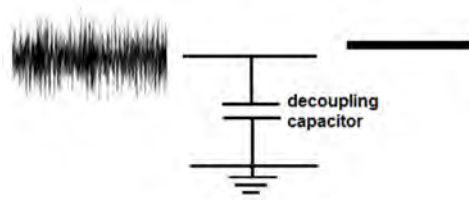

Figure 24.12: A decoupling capacitor is essentially a low-pass filter allowing low-frequency signal to pass through, while high-frequency signal is short-circuited (courtesy learningabout-electronics.com).

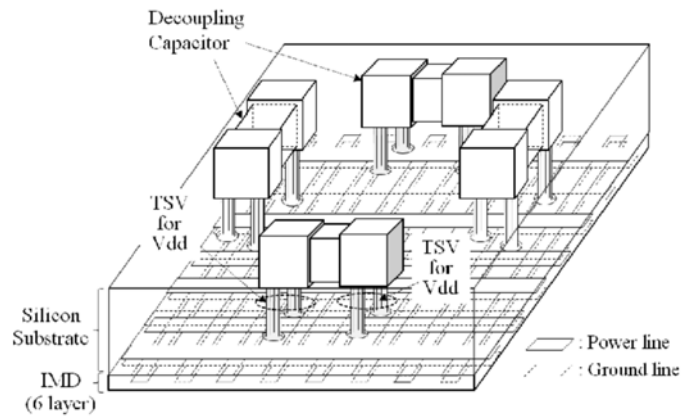

Figure 24.13: Modern computer chip design is 3D and is like a jungle. There are different levels in the chip and they are connected by through silicon vias (TSV). IMD stands for inter-metal dielectrics. One can see different XY lines serving as power and ground lines (courtesy of Semantic Scholars).

Inductors are also indispensable in IC design, as they can be used as a high frequency choke. However, designing compact inductor is still a challenge. Spiral inductors are used because of their planar structure and ease of fabrication. However, miniaturizing inductor is a difficult frontier research topic [135].

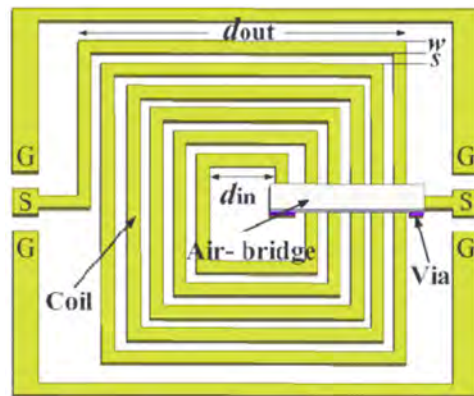

Figure 24.14: Spiral inductors are difficult to build on a chip, but by using laminal structure, it can be integrated into the IC fabrication process (courtesy of Quan Yuan, Research Gate).